

Company Profile & Sustainability

ABSTRACT 2023

DONATI

Notes



If you wish to receive a copy of our **Sustainability Report 2023 GRI Referenced** or if you would like to learn more about Donati's strategy and sustainability, please contact us at:
sustainability@donatiholding.it



1. COMPANY

06
Donati Holding
S.r.l.

07
A story of
Growth

08
Donati S.p.A.

10
Donati Glocal

13
Business
Model

15
Drivers of Donati's
Strategy

2. SUSTAINABILITY

18
Lowering the
Carbon Footprint

20
Creating a
Safe Product

24
Creating a Circular
Economy

3. PRODUCTS

29
Product Line:
Components

36
30 Years of
Epron

37
Services: Design
Ready by Donati

1.
Company

DONATI

Donati Holding Srl

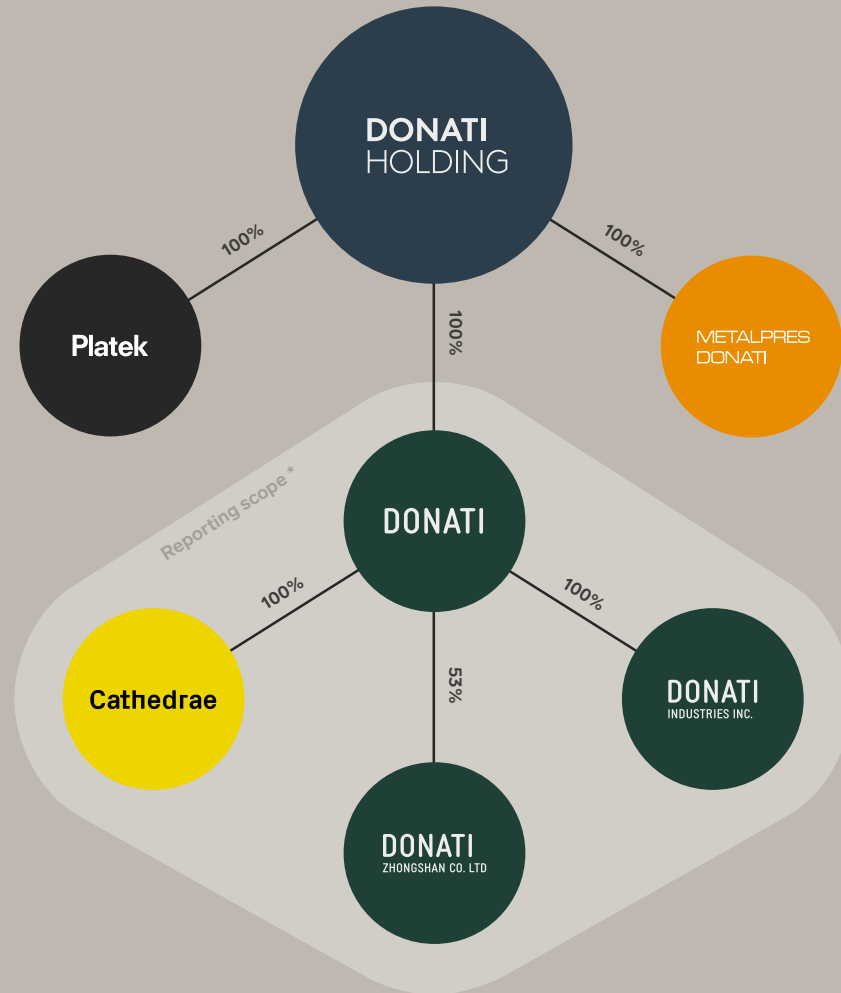

Donati S.p.A. belongs to Donati Holding, which operates in 3 industrial sectors.

Metalpres Donati S.p.A.

AUTOMOTIVE AND CHAIR COMPONENTS IN ALUMINIUM

Platek S.r.l.

OUTDOOR LIGHTING

Donati S.p.A. Zhongshan Donati Co. Ltd

Donati Industries Inc.

Cathedrae S.r.l.

CHAIR COMPONENTS

YEARS	2021	2022	2023
REVENUES	€141M	€168M	€151M
INVESTMENTS	€11M	€14M	€10M

A Story of Growth

- Donati
- Metalpres Donati
- Platek

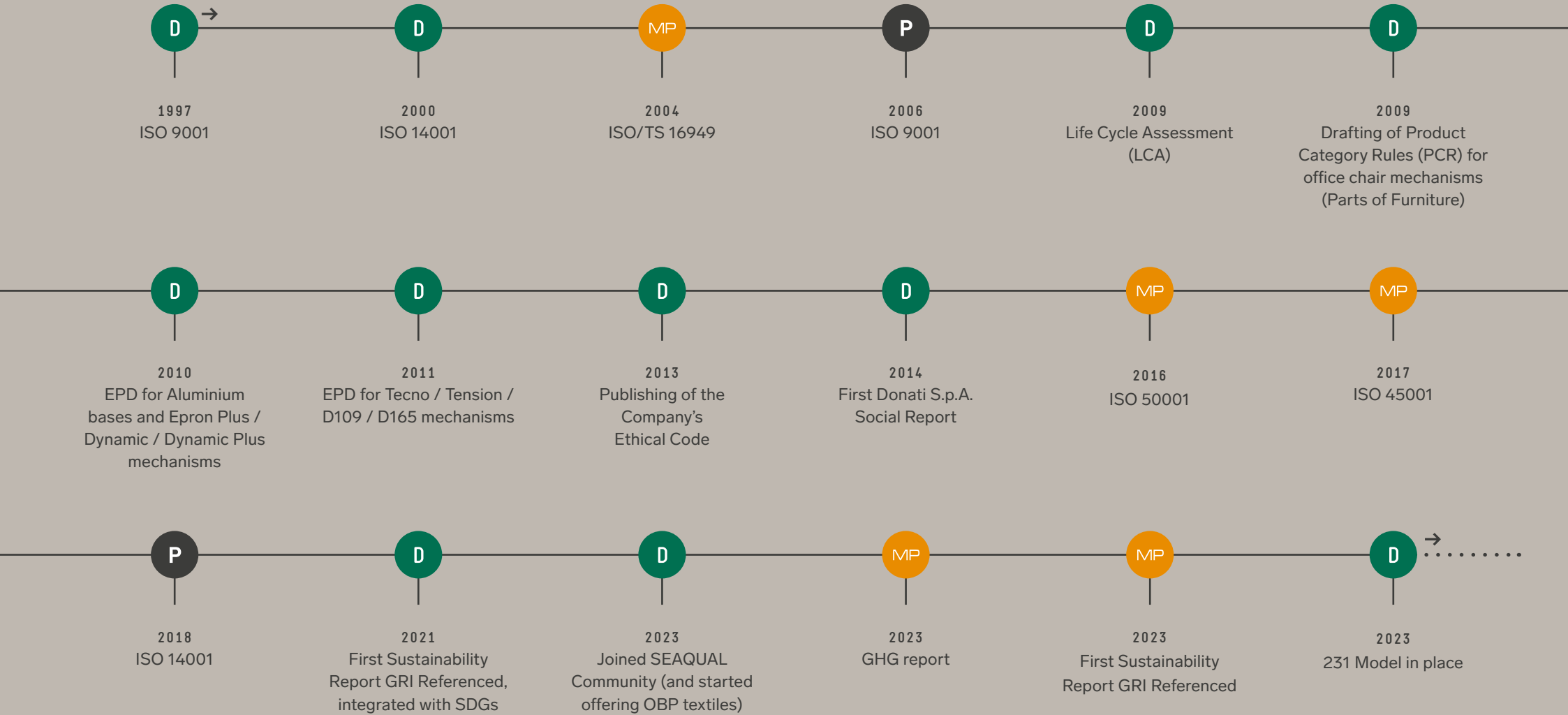

Donati S.p.A.



Donati is an international company dedicated to manufacturing for the world's best furniture brands.

Since 1990, Donati has been a family-owned company that combines passion for manufacturing with sensitivity for design, a strong background in engineering and excellence in execution.

Our production is vertically integrated and our manufacturing sites are distributed over Europe, Asia and North America. This makes us an independent and reliable partner in global markets. The Headquarter of the Company is located in via Paderno 19, Rodengo Saiano (BS), Italy.

Company Locations — Italy

Headquarter &
Production plant

Production plant

Production plant

Logistics

Production plant



ADDRESS

Rodengo Saiano (BS)
via Paderno, 19

TOTAL AREA

14.000 m²

COVERED AREA

8.000 m²

EMPLOYEES

84

ACTIVITIES

Offices
Mechanisms assembly

ADDRESS

Passirano (BS)
via Adua, 76/90

TOTAL AREA

22.400 m²

COVERED AREA

12.000 m²

EMPLOYEES

30

ACTIVITIES

Plastic injection moulding

ADDRESS

Passirano (BS)
via Adua, 56/64

TOTAL AREA

10.900 m²

COVERED AREA

6.700 m²

EMPLOYEES

53

ACTIVITIES

Mechanical processing
Surface finishing

ADDRESS

Passirano (BS)
via Fratelli Rosselli, 11

TOTAL AREA

50.160 m²

COVERED AREA

9.240 m²

EMPLOYEES

3

ACTIVITIES

Logistics

ADDRESS

Gissi (CH)
Via Zona Industriale, 1

TOTAL AREA

7.000 m²

EMPLOYEES

25

ACTIVITIES

Plastic injection moulding

Donati Glocal

One of Donati Group's principles is to manufacture the product **where it is used.**

Over the years, the number of international customers has grown significantly and for this reason the Company has decided to invest in additional production sites close to its Asian and North American customers.

In addition to assembly and logistics, the foreign plants have their own production of components, to ensure just-in-time deliveries to its clients' local factories.

Overseas teams lead Donati's local production and coordinate the activities with the Headquarter in Italy, which continues to be in charge of all European production as well as product development, overall quality assurance and all the other typical functions of the Headquarters.

DONATI INDUSTRIES, INC.

Michigan, USA

DONATI S.P.A.

Lombardy, Italy

ZHONGSHAN DONATI CO. LTD

Guangdong, China



Donati Glocal — Cina & USA



Zhongshan Donati (Production plant)

LOCATION

Guangdong, Cina

TOTAL AREA

20.000 m²

EMPLOYEES

157

ACTIVITIES

Offices
Plastic injection moulding
Aluminium foundry
Surface finishing
Assembly
Logistics

In 2007, Donati opened its own factory in China to provide high quality and Italian design to the Asian market. In just a few years, Zhongshan Donati experienced a strong and continuous growth, and in 2015 a department entirely dedicated to plastic molding was established. With 14 injection molding machines of 3-1,800 tonnes, the Chinese Company now produces plastic components (specifically; polyamide, polypropylene, polystyrene, ABS, thermoplastic elastomer and polycarbonate).

In 2018 Zhongshan Donati also started aluminium die-casting, mechanical machining and polishing.

In addition to the know-how acquired in production, Zhongshan Donati has become an expert partner in the design and development of components, both standard and customized. The Company analyses and evaluates design proposals in order to propose improvements and modifications with the aim to maximize the performance of the component.

Zhongshan Donati produces for the world's leading brands in the office chair sector and offers its clients the opportunity to develop an exceptional product in terms of innovation, quality, design and sustainability.



Donati Industries (Production plant)

LOCATION

Holland (Michigan), USA

TOTAL AREA

4.000 m²

EMPLOYEES

12

ACTIVITIES

Offices
Plastic injection moulding
Assembly
Logistics

North America represents a very large and important market for the office furniture sector, with multinational companies having a high reputation on the global market.

With the aim to increase its presence and collaboration with local companies, in 2008 Donati founded Donati USA, a company based in North Carolina and focused on just-in-time distribution in the American continent.

Then in 2017, Donati Industries Inc. was also established as a plastic injection molding unit for the north American market. Donati Industries Inc. has established itself as a key hub able to meet the needs of clients in North America.



Business Model

The whole value chain in one place:
From the **idea** to the **finished product**.

Donati is proud to offer the complete value chain: the Company follows the project from the initial idea to the engineering and production of components and complete office chairs, distributing them on an industrial scale while always maintaining attention to detail and uniqueness typical of the artisan tradition.

The main phases of Donati business model are:

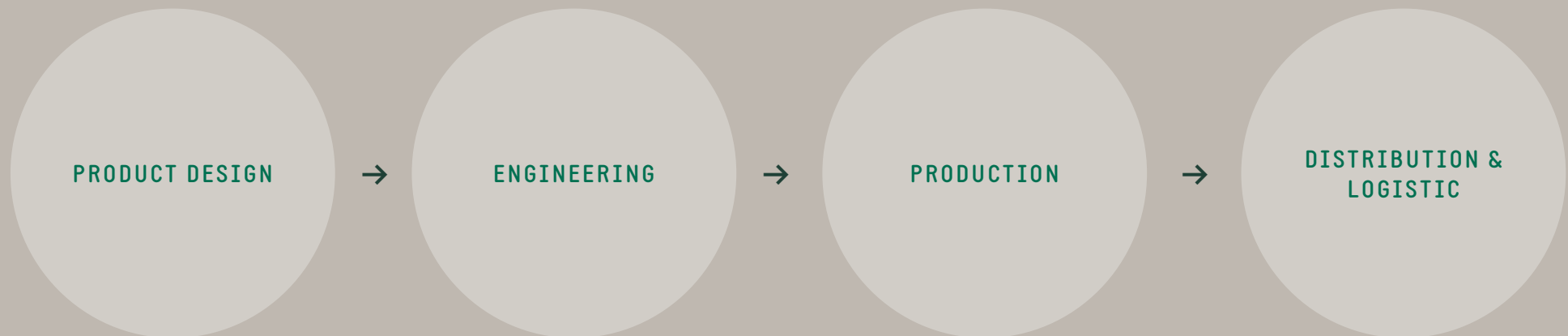

Business Model

Other features of Donati's business model are:

- **Standard products** from the catalogue are readily available
- **Donati designs, plans and industrializes** customized components
- **Flexibility:** Donati offers a combination of different partnership models based on the customer needs



Technical Department

Donati's technical department, with its experienced engineers and designers, bring ideas to life thanks to their competences and the cutting-edge technologies at their disposal.



Design Platform

The showroom of Donati headquarter was transformed into a platform of creation and exchange, a design laboratory to create new ideas relating to seating and components.

Drivers of Donati's Strategy

For Donati, **innovation** has always been the **core** around which **ideas, projects, design, products and processes evolve.**

1. Innovation for Quality (I4Quality)



DONATI CONSIDERS INNOVATION AS A DRIVER FOR MAINTAINING THE HIGH QUALITY AND SAFETY THAT CHARACTERIZES ITS PRODUCTS AND ON WHICH ITS REPUTATION AND BRAND PERCEPTION IS BASED.

2. Innovation for Process (I4Process)



DONATI HAS ALWAYS WORKED TO INNOVATE PRODUCTION PROCESSES, TO OPTIMIZE THE PRODUCT MANUFACTURING CYCLE AND TO MAXIMIZE TIME, ALSO THROUGH THE USE OF ENABLING TECHNOLOGY.

3. Innovation for Design (I4Design)



THE DESIGN OF DONATI COMPONENTS HAS ALWAYS BEEN THE RESULT OF A STUDY TOWARDS THE SEARCH FOR BEAUTY, COMBINED WITH THE FUNCTIONALITY AND QUALITY OF EACH INDIVIDUAL PIECE.

4. Innovation for Sustainability (I4Sustainability)



FOR DONATI, SUSTAINABILITY IS NOT ONLY A VALUE BUT ALSO A STRATEGIC BUSINESS TARGET. THE COMPANY'S PURPOSE CONSISTS OF IMPLEMENTING A POLICY BASED ON THE PERFECT SYMBIOSIS BETWEEN THE USE OF THE BEST AVAILABLE TECHNOLOGY, THE INCREASING SOURCING OF RECYCLED RAW MATERIALS AND THE REDUCTION OF EMISSIONS – THREE FUNDAMENTAL FACTORS IN THE PERSPECTIVE OF THE CONTINUOUS IMPROVEMENT.

65 Patents

**486 Protected
Products**

**683 Customized
Products From
2019 to 2023**

2.

Sustainability



Company Carbon Footprint – Scope 1

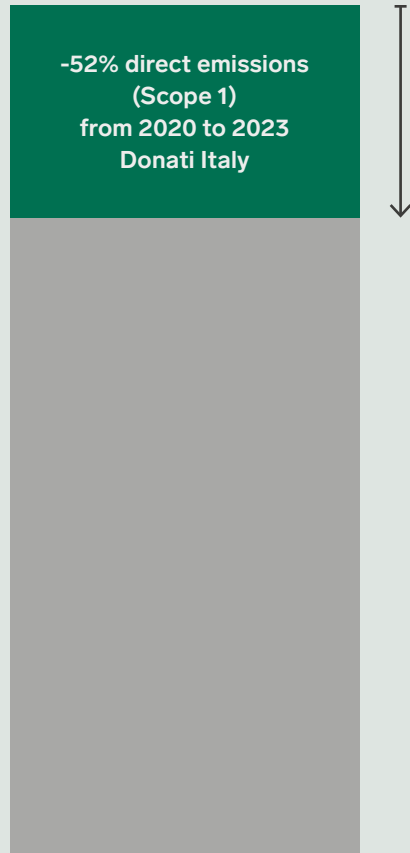

DIRECT EMISSIONS Scope 1 (in tCO₂e)* – Donati Italy / China / USA

	2020	2021	2022	2023
SCOPE 1 TOTAL DIRECT EMISSIONS	984,04	929,65	793,89	528,61

DIRECT EMISSIONS Scope 1 (in tCO₂e)* – Donati Italy

	2020	2021	2022	2023
SCOPE 1 TOTAL DIRECT EMISSIONS	658,12	627,78	496,52	343,76

*Source of the emission factors: DEFRA

Company Carbon Footprint – Scope 2

21% of the electricity consumption of Donati Italy is self-produced from renewable energy.



Photovoltaic system	Total power → 3210 kWp
RODENGO SAIANO – VIA PADERNO, 19	
GISSI – VIA ZONA INDUSTRIALE, 1	
PASSIRANO – VIA FRATELLI ROSSELLI, 11	
PASSIRANO – VIA ADUA, 56	
PASSIRANO – VIA ADUA, 64	

INDIRECT EMISSIONS Scope 2 (in tCO ₂ e)* – Donati Italy / China / USA				
	2020	2021	2022	2023
MARKET-BASED METHOD	4.452,05	5.096,02	5.017,25	4.523,71
LOCATION-BASED METHOD	3.328,68	3.649,11	3.570,73	3.487,98

INDIRECT EMISSIONS Scope 2 (in tCO ₂ e)* – Donati Italy				
	2020	2021	2022	2023
MARKET-BASED METHOD	2.708,73	3.510,57	3.509,63	2.889,74
LOCATION-BASED METHOD	1.585,36	2.063,66	2.063,11	1.854,01

*Source of the emission factors: European Residual Mixes “AIB” for Italy and Terna Confronti Internazionali 2019 for China and USA.

Creating a Safe Product



Donati makes high quality products, with recyclable raw materials.

To guarantee its customers a safe and reliable product, Donati carries out a rigorous control of its suppliers and materials according to the highest standards. For each material used, in addition to collecting safety data sheets, the Company ensures compliance with European regulations: REACH, CLP, RoHS, POP, Conflict Minerals, California Proposition 65.

Donati guarantees the quality and safety of the products through its technical laboratory which uses 22 tests stations, designed to verify safety and fatigue resistance of the seats.

Materials are then classified on the basis of the main non-mandatory environmental certifications in the field of furniture: Nordic Swan Ecolabel, Möbelfakta, Ecolabelling Denmark, Der Blauer Engel, Cradle to Cradle, LBC, BIFMA.

Creating a Safe Product

Paints



The paints used (epoxy powders) have been verified and chosen above all on the basis of their safety: no mixture used contains volatile organic compounds (VOC), PFAS or SVHC > 0.1%.

Creating a Safe Product

For its components and products and for customer projects, Donati **guarantees** all relevant international certification processes, such as **BIFMA** or **EN 1335**.

This includes pre-testing during the prototyping and construction phase, as well as the final verification of conformity of the product before it is launched on the market.

Donati has also a metrological laboratory, equipped with cutting-edge instruments, including CMM and 3D scanner. Specific quality tests are also carried out at Donati Zhongshan in China and Donati Industries in America.

Other procedure in place for the management of the Supply Chain:

- Periodic questionnaire
- Periodic audit
- Code of conduct
- Supply specifications

In 2023 Donati made:

675
Laboratory
Tests

2.103
Static Tests
for Rupture



Creating a Circular Economy

With a view to pursuing a **circular economy** policy, Donati is actively committed to prolonging the life cycle of raw materials by **using recycled and recyclable materials as much as possible.**



It is an important goal in Donati sustainability strategy, to increase the use of recycled raw materials within its value chain.

For this purpose, a dedicated working group (**Circulariteam**) has been set up and it meets periodically to carry out research, analysis and feasibility study with regard to sustainable materials.

Creating a Circular Economy

To increase recyclability of its products over the years the technicians have approached eco-design, studying therefore more efficient solutions for assembly and disassembly of the product. All Donati components are easily separable and recyclable. In addition, to ensure proper recycling, each component is marked according to UNI EN ISO 11469:2001 and ISO 1043.

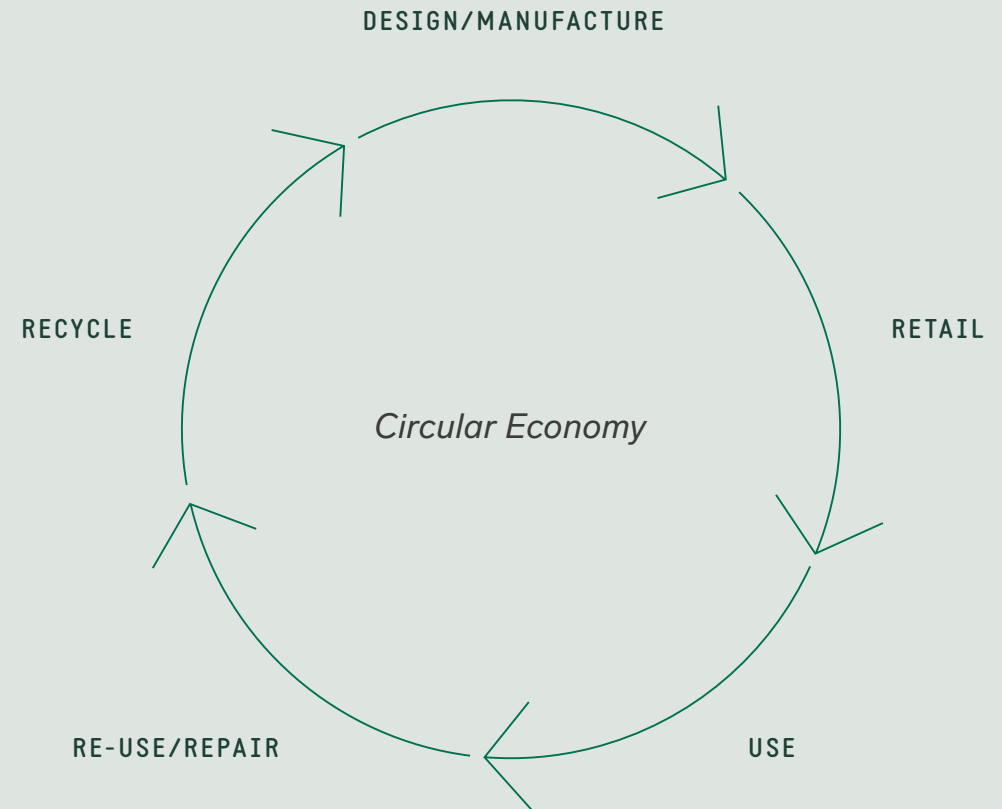

Creating a Circular Economy Aluminium

The aluminium used by Donati comes entirely from recycling activities. The only non-recyclable additive is, in fact, silicon metal, which is added to the alloy to improve smoothness and mechanical strength in the process of forming pieces.

Recycled content of the aluminium alloy: 97%

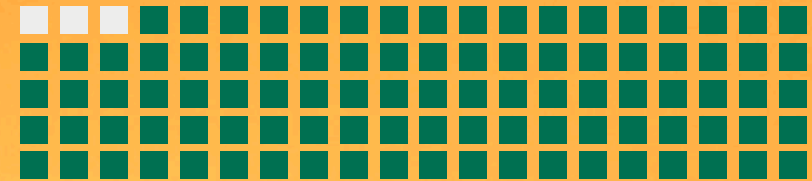

Recycled aluminium, compared to primary mineral aluminium, saves 95% of the energy used and GHGs emitted. Each ton of recycled aluminium therefore saves 14.000 kWh of energy and 9 tons of CO₂ in comparison to aluminium from bauxite (Sources: Geopop, IAI/EAA).

Aluminium is also a very sustainable metal as it can be recycled indefinitely, without losing its technical and mechanical properties. In addition, the melting point is relatively low, therefore allowing further energy savings. Other important characteristics of aluminium are lightness, ductility and resistance.

In fact, aluminium does not absorb liquids or odours and it does not deteriorate with exposure to light. It generates natural oxide, which protects the surface from corrosion and the finished product does not need special maintenance.

-95% energy consumption



From -95% to -97% CO₂ emitted

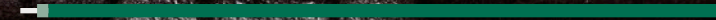

Creating a Circular Economy Plastics

-96% CO₂ emitted



-40% natural resources consumption



From -25 to -40% energy consumption



-80% water consumption



-60% non-renewable resources

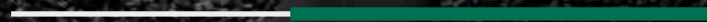

In addition to aluminium, Donati also uses plastic, in particular: polyamide, polypropylene, abs and acetal resin.

Donati Industries in America uses plastic which comes from recycled material, with a variation of recycled content ranging from 69% to 100%. Donati Spa in Italy produces its black nylon bases with recycled PA6, while for the other components, the Company has set up a working group whose aim is to implement the use of recycled materials.

Zhongshan Donati in China is also committed to the use of recycled materials, but the parameters are lower than the other plants; this is due to the intrinsic characteristic of the raw material market in which the Company operates.

Plastic is a recyclable and lightweight material and the use of recycled plastic allows significant savings in CO₂ and consumed resources. The energy saves with the use of recycled granules, rather than plastic extracted from petroleum, ranges from 25% to 40%, with a saving of natural resources of 40% (Source: supplier A).

Furthermore, to produce one kg of virgin PA6, 6,5 kg of equivalent CO₂ is emitted into the atmosphere, compared to 0,22 kg of equivalent CO₂ emitted in the production of one kg of recycled granule, thus allowing a high reduction of CO₂ emitted. In addition, non-renewable resources can save up to 60% and water up to 80% (Source: supplier B).

3.
Products



Product Line: Components



Donati develops and produces **furniture components** for office chairs, contract and residential.

A wide selection of products is readily available in the standard range, which can be consulted in the General Catalogue and also available online. The bases, footrests, armrests, seats, backrests and mechanisms are all part of the same modular system and as such they can easily be grouped into larger functional families or even complete chairs.

For over thirty years, Donati has been highly specialized in mechanisms for chairs, from small integrated tilt mechanisms to synchronized multi-adjustable or self-adjusting weight-activated mechanisms. Continuous investments in research have led to the obtaining of patents for several generations of innovative movements and cutting-edge types.

Die-cast aluminium bases or injection-moulded plastic bases constitute another of the most innovative products within the framework of sustainability as they are made almost entirely with recycled raw materials.

In addition to the standard range, Donati also offers individual solutions for furniture components as the Company develops the customers' ideas from scratch and offers the customization of standard components in tailor-made versions.

Product Line: Components

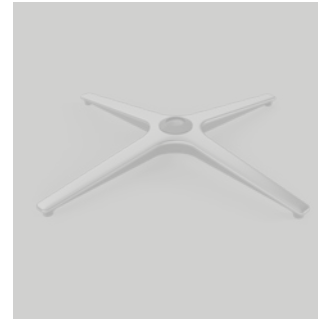

Synchro and Multi-tilt Mechanisms

Synchro mechanisms allow the seat and the backrest to move simultaneously through a pre-set ratio: the variation in inclination of the seats corresponds to a certain variation in inclination of the backrest. On the other hand, multi tilt mechanisms only allow the inclination of the backrest, independently from that of the seat, which can be fixed or manually adjustable by the user.

Synchro tilt mechanisms

- Epron RV — Epron Plus — Epron — Epron Solo
- Core — D165 — Dynamic Plus — Tecno — Epsilon

Multi-tilt mechanisms

- Epron Plus Asynchron — Epron Asynchron

Product Line: Components

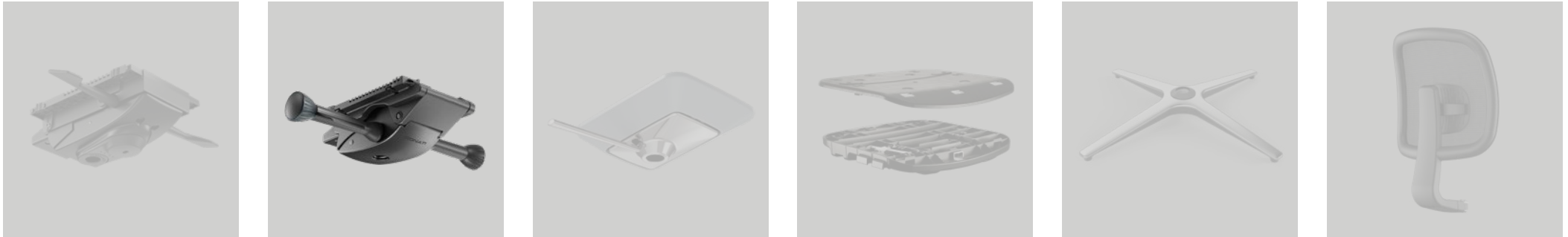

Weight-activated synchro tilt Mechanisms

Weight-activated mechanisms are a variant of synchro mechanisms: they have the same characteristics as the synchro mechanism with the addition of being able to automatically adjust the force response on the backrest in relation to the weight of the user. This adjustment takes place through a specific geometric configuration of the rotation axes of the moving elements (backrest and seat) and allows to obtain immediate comfort in comparison to simple synchronized mechanisms which requires manual adjustment, instead.

Weight-activated mechanisms

— Friendly — Dopotutto — Inedito — D109

Product Line: Components

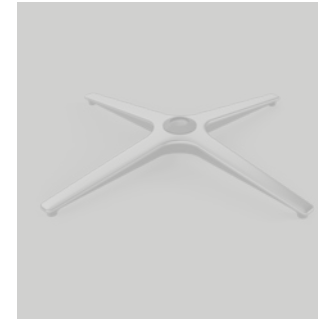
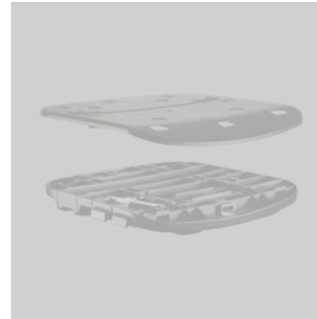

Fixed Supports and Tilt Mechanisms

Fixed supports and tilt mechanisms are used on monoshell type of chairs, where the backrest and the seat are a single element or connected to one another.

Fixed support are simple connection elements between the gas cylinder and the chair.

Tilt mechanisms, on the other hand, allow the movement of the chair to improve comfort.

Fixed supports

— Superleggero — Spider — Plane 100%

Tilt mechanisms

— Instar — Armonico — MPD38 — D165

Product Line: Components



Bolt-on and Quick Connection Seats

Donati seats are divided into two main categories: traditional fixing seats (the seat and the mechanisms are assembled together with screws) and quick connection seats (the connection between the seat and the mechanisms doesn't require any screws, through a unique click-in system).

Quick connection sliding seats make the assembly quick and easy, also in case it is the end user assembling the chair.

Fixed/sliding bolt-on seats

— Slim — Conka — Dash — Flat

Quick connection sliding seats

— Trasla 2 — Trasla 3 — Trasla 4 — Kite

Product Line: Components

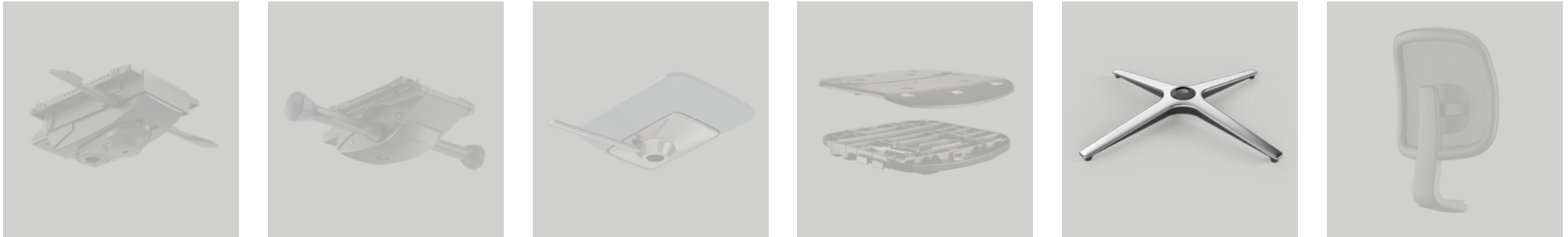

Aluminium and Nylon Bases

There are two main categories of Donati bases and they are divided according to the type of material: aluminium or nylon. The choice of material depends on the type of use, the target price and the desired surface finish. To best meet the market demands, most of Donati bases are designed to be made in both materials. For some years now, Donati has introduced a new and unprecedented category of bases: the pivoting bases. The peculiarity of this new collection of products is that these bases have a special hidden joint built inside the cone, which allows the seat to swing, thus increasing comfort while seated and avoiding the need of a tilting mechanism underneath the seat.

Tilt bases

— Trevi XL — Abaco — Ziggurat

Aluminium bases

— Trevi XL — Trevi — Abaco — Quoin
— Superleggera — DB1.8 — DB2.13 — B.Kros
— DB1.13 — DB1.17 — B.You — Meteora — DB2.6 — Presto — B1
— B1T — K600 — K720 — L1080 — L2080 — DB1.6 — DB1.9 — L1023 — Octopus
— Unica

Nylon bases

— Ziggurat — Disko — Quoin — DB2.13 — DB1.8 — DB1.13 — Meteora — DB2.6 — Presto — B1T
— DB1.9 — DB1.6

Product Line: Components

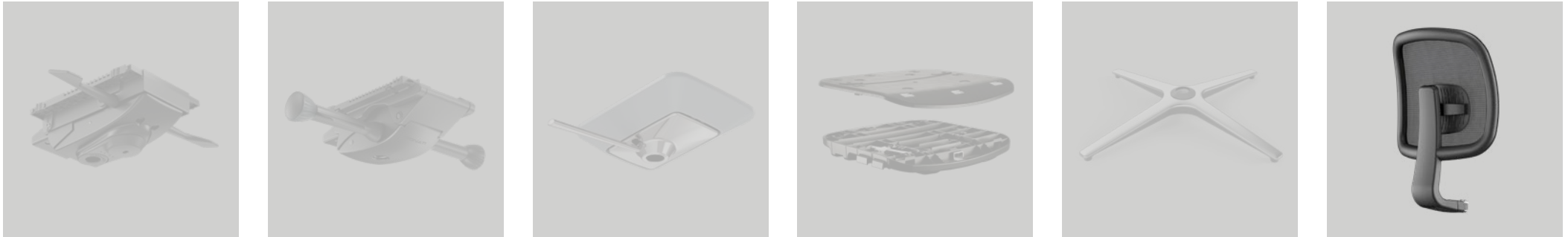

Other components: Backrests, Arms, Footrests, etc.

Donati produces other products and accessories which belong to the office and contract world: backrests, adapters for wooden/nylon seats, armrests, backrest supports, footrests and gliders for bases.

Backrests

— Clipper — Why — Kiva

Adaptors for seats

— Modula 1 — Piastra Adattatore — Trasla

Armrests

— BeO — Nedo

Backrest supports

— Activa — Up/Down

Footrests

— Trim — D.17 — L1060 — L1065

30 Years of Epron

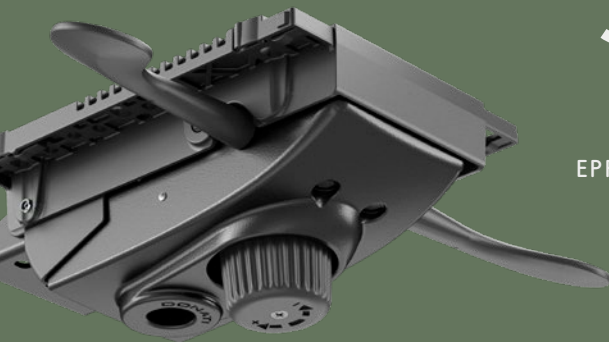

EPRON

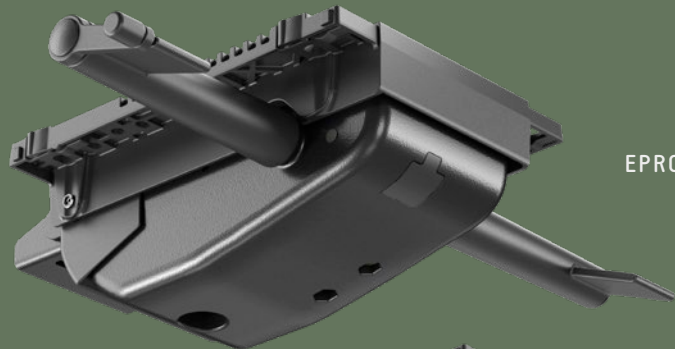

EPRON PLUS

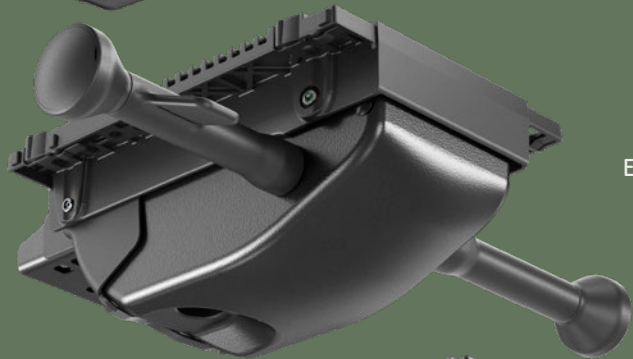

EPRON RV

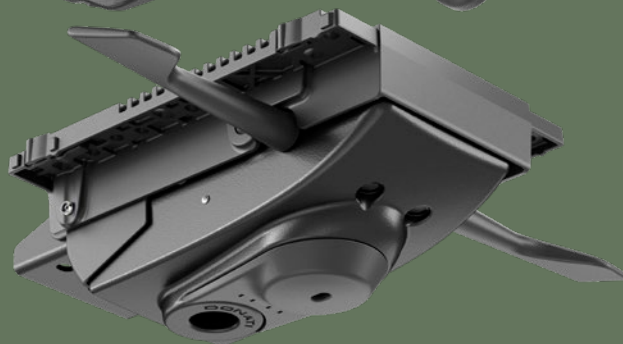

EPRON SOLO

History and Evolution of Donati's Top Mechanism

1996	Creation of the Epron mechanism, the first mechanism equipped with an anti-shock backrest release system. The anti-shock system allows to free the swing of the backrest from a locked position, without it jumping forward. The user activates the movement of the backrest with the weight, leaning on the backrest and moving back slightly.
1997	Growth of the Epron family with the Flex and Asynchron versions.
2000	Restyling of the aluminium housing and levers by architect Gamberini.
2001	Further growth of the Epron family with the Cable version.
2007	Creation of the Epron Plus to meet the market needs: lateral spring adjustment. Epron mechanism in fact has a spring tension adjustment in the lower part.
2014	Introduction of the universal nylon plate, which allows to mount both quick connection sliding seats and traditional fixed seats (with screws). The final disposal of the iron plate dates back to 2017. The market showed the need to develop a mechanism with a spring tension adjustment with fewer handwheel turns: this was the creation of Epron RV, an evolution of the Epron Plus mechanism. Connected to the seat only with a universal plate, Epron RV is a success, with its softer shapes and rapid comfort adjustments. Epron RV has also been adopted by Herman Miller (now MillerKnoll) for some of its chairs, after a series of very demanding endurance tests.
2019	Creation of Epron Solo, an entry-level mechanism with an aluminium housing identical to the original Epron and oscillation through the conventional spring (wire) or cellasto. The adjustment levers undergo the most significant redesign: they are located at the same level of the seat regulating the locking/unlocking of the backrest.

Services: Design Ready by Donati

Design Ready by Donati presents **concepts for technical seating.**

The products - such as office and studio chairs, conference or executive chairs - are initiated by Donati's product engineers together with international designers and then finished and brought to market by Donati's industry clients.

Design Ready products enable furniture brands to expand their portfolio quickly and inexpensively. With design being pre-defined and engineering well advanced, Donati's industry clients simply need to specify their individual functionality and design details.

Donati will then finalise development and deliver a complete product in a short time. This is why the new business model is called Design Ready by Donati.

With Design Ready, Donati also provides a new platform of creation and collaboration between designers, furniture brands and the manufacturing industry. Recent design partnerships include some of the industry's most experienced designers as well as young studios for whom Design Ready offers an opportunity to bring their designs into production.



Services: Design Ready by Donati



Elle: Light task chairs platform

Elle is a versatile chair for office and soft contract, it looks like a singleshell chair but it actually integrates a synchronized weight-activated mechanism. The technical platform allows for different back heights and armrest options in aluminium or nylon. The design is highly customizable according to the customer's preference.

An example is the LEN Chair (design: Giovanni Ingnoli).

DESIGN

Studio Tecnico Donati

Services: Design Ready by Donati



Ziggurat: Stool system

The Ziggurat product family consists in highly customizable stools, ideal for both work and hospitality environments. Ziggurat is a dynamic product family, with three seat shapes, fixed or pivoting bases. Moreover, each customer can customize the colours of the plastic parts, upholstery and finishing materials. To the stool options, Donati added also a height adjustable table.

DESIGN

Studio Tecnico Donati /
Baldanzi & Novelli designers

Services: Design Ready by Donati



Clipper: office chair

Clipper Chair is a lightweight office chair that offers high comfort at a competitive price. The mesh backrest allows the air to circulate, while the clip-on system allows for quick mesh assembly. Lumbar height adjustment is integrated by 70 mm, while the use of Donati universal connection interface guarantees a wide combination of mechanisms, seats, armrests and bases.

DESIGN

Studio Tecnico Donati /
Baldanzi & Novelli designers

Services: Design Ready by Donati



Unica: aluminum single-shell chair

Unica Chair is a modular chair system that combines die-cast aluminium shells, optional upholstery and different types of bases for both indoor and outdoor use.

The customer can obtain multiple distinctive versions with a low investment.

The shell and the profile of the chair can be customized with different shapes, decorative inlays, finishes, colours and materials.

DESIGN

Marcello Ziliani

Services: Design Ready by Donati



Cassia: working chair

The Cassia chair is a highly technical ergonomic instrument designed to optimize the pleasure of working.

Cassia is a new generation of ergonomic working chairs with a patented flexible seat principle. The flexible seat encourages a higher and dynamic perching position, reducing shear forces on the spine, increased blood-flow through the lower body and promotes more continuous, high quality movement. This is developed by Perch Studio, Dublin, with whom the designer of Cassia chair, Hans Thyge, has been collaborating for many years.

DESIGN

Hans Thyge & Co.

Services: Design Ready by Donati



Danny: studio chair

Danny is a multifunctional chair line ideal for both work and hospitality.

The propylene monocoque is what characterises this model, Danny can be completely customised: backrest, seat, armrest. The client can even choose to integrate the mechanism.

DESIGN

KlingerBordihn

Credits

COPYRIGHT NOTICE — TRADEMARKS

® Donati is a registered trademark of Donati S.p.A. — All rights reserved. All information and content on this document are the property of Donati S.p.A. or its licensors. The content is protected by copyright laws, trademark and design rights. Any unauthorized use of the content will be considered a violation of the intellectual property rights. Unless otherwise stated in this document, no content may be copied, distributed, published or used in any way, in whole or in part, without prior written agreement from Donati S.p.A.

EDITION 2024

Rev 00



Donati S.p.A.
Via Paderno, 19
25050 Rodengo Saiano (BS)
Italy

phone +39.030.6818711
fax +39.030.6810448
info@donati.eu

www.donati.eu